

Best Practice Statement ~ *March 2007*

Caring for the patient with a tracheostomy

© NHS Quality Improvement Scotland 2007

ISBN 1-84404-453-X

First published January 2003

Reviewed April 2007

You can copy or reproduce the information in this document for use within NHS Scotland and for educational purposes. You must not make a profit using information in this document. Commercial organisations must get our written permission before reproducing this document.

www.nhshealthquality.org



Contents

Introduction	i
Key stages in the development of best practice statements	ii
Best practice statement: Caring for the patient with a tracheostomy	iii
Section 1: Education and training	1
Section 2: Communication	3
Section 3: Swallowing and nutrition	5
Section 4: Stoma care	7
Section 5: Tracheostomy tube management	9
Section 6: Suctioning	14
Section 7: Humidification	15
Appendix 1: Volume of tracheostomies in Scotland	18
Appendix 2: Factors that affect communication	19
Appendix 3: Factors that may affect swallowing	20
Appendix 4: Types of tracheostomy tube	21
Appendix 5: Illustrations	22
Appendix 6: Audit tool	26
Glossary	28
References	30
Who was involved in developing the statement?	35

Introduction

NHS Quality Improvement Scotland (NHS QIS) was set up by the Scottish Parliament in 2003 to take the lead in improving the quality of care and treatment delivered by NHSScotland.

The purpose of NHS QIS is to improve the quality of healthcare in Scotland by setting standards and monitoring performance, and by providing NHS Scotland with advice, guidance and support on effective clinical practice and service improvements.

A series of best practice statements has been produced within the Practice Development Unit of NHS QIS, designed to offer guidance on best and achievable practice in a specific area of care. These statements reflect the current emphasis on delivering care that is patient-centred, cost-effective and fair. They reflect the commitment of NHS QIS to sharing local excellence at a national level.

Best practice statements are produced by a systematic process, outlined overleaf, and underpinned by a number of key principles.

- They are intended to guide practice and promote a consistent, cohesive and achievable approach to care. Their aims are realistic but challenging.
- They are primarily intended for use by registered nurses, midwives, allied health professionals, and the staff who support them.
- They are developed where variation in practice exists and seek to establish an agreed approach for practitioners.
- Responsibility for implementation of these statements rests at local level.

Best practice statements are reviewed, and, if necessary, updated after 3 years in order to ensure the statements continue to reflect current thinking with regard to best practice.

Key stages in the development of best practice statements

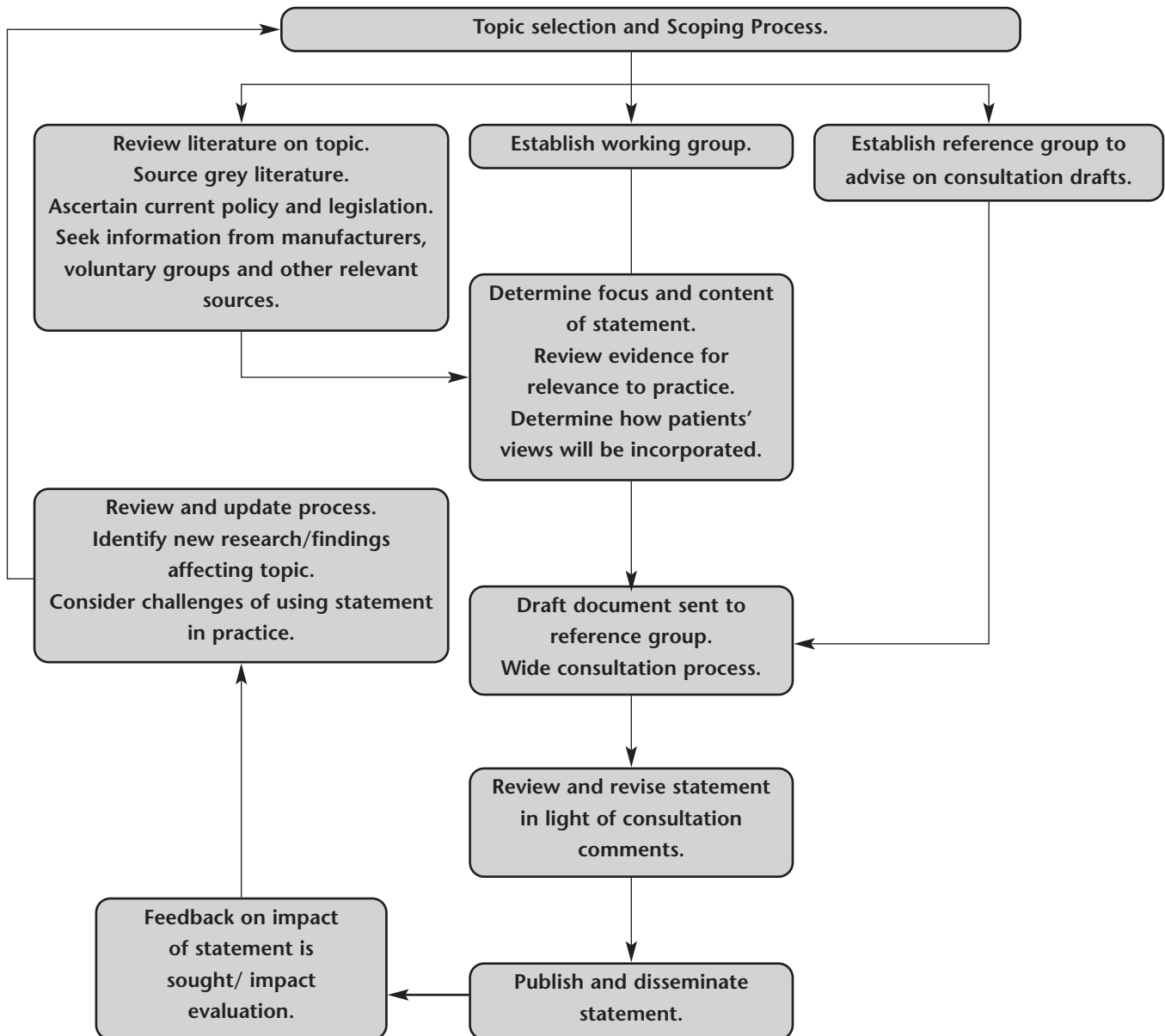

Best practice statement: Caring for the patient with a tracheostomy

A tracheostomy is an opening in the front of the trachea that can be temporary or permanent. Temporary ones usually have a tracheostomy tube in place to keep them open. Indications for the formation of a tracheostomy will include protection from aspiration in cases of swallowing impairment, to facilitate breathing and weaning from artificial ventilation and to facilitate clearance of secretions. Examples of patients who may have a tracheostomy are those with neuromuscular disorders who have impaired swallowing and coughing, those who have a poor cough or gag reflex after a head injury or a protracted critical illness and patients who have had their larynx removed surgically. As with the original, this revised statement does not refer to care of patients with a laryngectomy.

The different nature of the situations in which a tracheostomy could be employed means that it is difficult to track the epidemiology of this procedure. Due to the increasing sophistication of medical technology and higher survival rates from diseases such as motor neurone disease, the incidence of tracheostomy in general wards and in the community is increasing. In Scotland, the volume of tracheostomy operations over the last decade has increased (Appendix 1). In 2002, the Ear, Nose and Throat (ENT) Nursing network from the Nursing and Midwifery Practice Development Unit, which subsequently merged with other organisations to become NHS QIS, identified this topic as one where guidance and support in the form of professional consensus would help promote consistent practice across Scotland.

This statement was originally designed for healthcare professionals, especially nurses, who may not necessarily work in a specialist environment and where there is access only to professional support available as 'outreach' from specialist clinical areas. The management of a tracheostomy involves other professionals such as dietitians, physiotherapists, specialist nurses, and speech and language therapists. The membership of the working groups convened first to develop the statement and then to review it reflects this.



In reviewing the statement, it was agreed that little new formal evidence with the potential to change practice had been published since the statement had been first developed. Information gathered from users of the statement as part of the review process suggested that the revised statement should refer only to adults.

The working group identified several significant principles to consider when caring for the patient with a tracheostomy. Firstly, there is a need to acknowledge that there will be differences between the practices and procedures involved in caring for a patient with a tracheostomy who lives in the community, and where the stoma is established, to those which are typical of intensive care units (ICUs) and specialist wards, eg thoracic wards, where the stoma is relatively new.

Secondly, the working group, recognised that in addition to the continuum of management requirements, there is a continuum of factors which come into play in the patient journey. There is a requirement, for example, to cater for the psychological, nutritional and communication needs of the patient which may also vary along the care pathway as the balance of risks changes.

This statement is designed primarily for the non-specialist practitioner, as an introductory statement and as a guide to best practice and what support should be available locally. The working group acknowledges, however, that some specialist units have used the statement. It is not designed as a 'how to' document, since the group envisage that local protocols and agreements will determine this, but where professional consensus exists on particular procedures, this is recorded in the statement. The statement will support local policies and procedures. It is the hope of the Practice Development Unit that, in time, the best practice statements will stimulate research and the development of a more formal evidence base; the statements are targeted at areas of clinical practice where the formal evidence base is still in the process of being developed and where there is a variation in practice across Scotland.

Since the statement was first published, the concept of risk management has become more familiar to healthcare practitioners, and the working group reviewing the statement was keen to stress that any consideration of the patient with a tracheostomy should be within such a risk management framework. Examples of this could include consideration of

the risk of occlusion, the risk of infection and the realistic management of cuff pressure testing in the community. Similarly, the working group discussed suctioning pressures, aware that this is a high risk procedure, and emphasised that the lowest possible pressure should be used, recognising that, as in all situations, the professional practitioner will be responsive to the context and address relative risks accordingly. In addition to acknowledging risk, the group recognised that all healthcare workers have a professional responsibility to ensure they have the knowledge and skills necessary to care for the patient with a tracheostomy. A separate section on education and training in the revised statement highlights the importance of this.

Since the publication of the original statement, the group acknowledged that an increased awareness of the special resuscitation requirements of patients with a tracheostomy is necessary and patient safety information from the National Patient Safety Agency (2005) has drawn attention to this. If the number of people with a tracheostomy in Scotland is increasing, as the data from ISD would suggest (Appendix 1), there is a need for enhanced awareness-raising in resuscitation training.

In addition to keeping technical skills at a suitable level, which is mandatory for professionals, good communication skills are very significant; not only in relieving anxiety in the patient, but also in involving the carer and educating both to undertake confident self-care in the community. This is particularly important where there are additional factors affecting the patient's capacity to communicate such as visual impairment, a learning disability, or the patient's use of English as a second language.

The statement focuses on the physical care of the patient, but the working group recognises that psychological support may well be necessary if the patient with a tracheostomy is to be integrated successfully into the community and that the best care will go beyond the recognition and addressing of physical need.

Responding to requests from users of the original statements, this revised version contains an audit tool. This could be used for the individual healthcare practitioner to monitor his or her own practice with an individual patient, or by a ward or larger service unit.



Section 1: Education and training

Key Points ~

- 1 *There is an increasing incidence of patients with a tracheostomy both in hospital and in the community. NHS boards have a responsibility towards these patients and also for preparing healthcare staff to care for them.*
- 2 *A patient-centred approach, good communication skills, and technical competence are required to care for, assure and assist patients in adapting to and managing a tracheostomy.*
- 3 *Patients and their carers require education and support in adapting to and living with a tracheostomy.*

Statement	Reasons for statement	How to demonstrate statement is being achieved
<p>Healthcare practitioners caring for a patient with a tracheostomy have access to:</p> <ul style="list-style-type: none"> • education and training to meet local need, and • standardised local protocols or guidelines developed by local specialists. 	<p>Healthcare professionals need to be equipped with the appropriate knowledge and skills to meet the unique needs of these patients competently and effectively.</p>	<p>There are local training and education opportunities for healthcare professionals to meet local need.</p> <p>There are local protocols or guidelines to support staff caring for the patient with a tracheostomy.</p>
<p>Healthcare practitioners who come into contact with a patient with a tracheostomy (no matter how infrequently) understand:</p> <ul style="list-style-type: none"> • the particular indications for tracheostomy • risks associated with a tracheostomy • potential complications • the types of tubes and equipment involved in each case, and • the importance of Standard Infection Control Precautions (SICPs). 	<p>It is a professional responsibility to be able to address patient needs competently.</p>	<p>Education is provided to develop and update knowledge of healthcare professionals working with patients with a tracheostomy.</p>
<p>Healthcare professionals and carers who are in contact with tracheostomy patients have access to and receive training on:</p> <ul style="list-style-type: none"> • airway, and • ventilation management of patients with a tracheostomy. 	<p>It is the professional responsibility of healthcare staff to be prepared and competent to deal with emergency situations.</p>	<p>Resuscitation training specific to patients with a tracheostomy is audited, and tailored to local need.</p> <p>Staff personal development plans identify resuscitation training requirements for relevant professionals.</p> <p>Key staff identified as competent are readily available to attend to emergencies.</p>

Statement	Reasons for statement	How to demonstrate statement is being achieved
<p>Healthcare professionals know when to seek, and have access to, professional advice and assistance from the relevant specialists on the:</p> <ul style="list-style-type: none"> • complex nutrition • chest physiotherapy • infection control • communication • resuscitation, and • specialist equipment requirements of patients with a tracheostomy. 	<p>Professional discrimination is required to identify the point at which it is appropriate to seek specialist advice, eg from physiotherapists, dietitians, and speech and language therapists.</p>	<p>There are clear lines of communication and agreed arrangements between the different healthcare professionals who may be required to provide care for the patient with a tracheostomy.</p>
<p>Healthcare professionals maintain competency in caring for a patient with a tracheostomy.</p>	<p>It is a professional obligation to maintain competency.</p>	<p>There is evidence of competency based training and education provision for relevant healthcare staff.</p> <p>Personal Development Plans reflect the level of competency achieved or required.</p>
<p>Education and reassurance of the patient and carer starts prior to a tracheostomy being performed and continues through the patient journey.</p>	<p>In addition to care, healthcare professionals are instrumental in inspiring confidence and offering support to patients with a tracheostomy.</p>	<p>Records or audits of information given to patients and carers at particular stages of the patient journey demonstrate that appropriate information is conveyed effectively.</p>
<p>The education of patients and their carers, and access to advice and support is necessary if patients are to live successfully in the home environment.</p>	<p>Patients with a tracheostomy who receive adequate education and support can be safely transferred out of hospital to live in the community.</p>	<p>Patients and carers in the community have contact details of specialist help, eg a home ventilation team or tracheostomy nurse specialist.</p>

Key Challenges ~

- 1 Identifying the education and training needs of a diverse group of staff and addressing these needs within resource constraints.
- 2 Raising awareness of the specific resuscitation requirements of patients with a tracheostomy.

Section 2: Communication

Key Points ~

- 1 *The impact of the loss of normal voice following tracheostomy should not be under-estimated and, whenever possible, patients and their families should be prepared for this. Developing alternative means of communication, including the use of a speaking valve, is a vital part of care.*
- 2 *The speech and language therapist has a key role in the care of patients with a tracheostomy when there are communication difficulties.*
- 3 *Ventilator-dependent patients, with respiratory stability and the ability to vocalise, can achieve speech and should be considered for specialist speaking valves (Dikeman & Kazandjian 1995, Mananzo et al 1993, Tippets & Siebens 1991). Computerised speech output systems should be considered for patients with long-term communication problems (Dikeman & Kazandjian 1995).*

Statement	Reasons for statement	How to demonstrate statement is being achieved
Healthcare professionals are knowledgeable about communication problems associated with patients with a tracheostomy and factors that affect communication (Appendix 2).	Patients with a tracheostomy may have communication problems that affect their ability to interact and be involved in their own care.	In-service education to develop and update knowledge of nurses working with patients with a tracheostomy, including communication, is provided.
The healthcare practitioner should be aware of communication difficulties and recognise when to involve the speech and language therapist.	Attention is given to the psychological impact of the loss of voice.	There are written criteria for referral to the speech and language therapist.
A communication assessment starts pre-operatively for an elective tracheostomy.	Assessment allows problems with communication to be quickly identified and immediate action can be taken to minimise the consequences of these problems.	Communication assessment is documented in the patient record.
Specialist communication assessment by the speech and language therapist includes a history and physical examination. Initial assessment includes the patient's ability to see, hear, touch, write, understand, or use facial expressions such as smiling or coded blinking.	Patients with a tracheostomy may have complex communication needs and require a combination of approaches to minimise problems (actual or potential).	Where dysfunction is identified, appropriate recommendations for alternative methods of communication are made.
Following assessment, a communication care plan, recognising the involvement of families and carers, including consideration of a speaking valve, and specific to individual needs, is drawn up.	Successful management of communication problems and the use of speaking valves are only possible through involvement and education of families and carers.	There is an agreed protocol on the management of communication issues, including the use of speaking valves and potential involvement of the speech and language therapist to encourage vocalising techniques.

Statement	Reasons for statement	How to demonstrate statement is being achieved
Healthcare professionals plan, implement and evaluate the communication care plan specific to the patient's needs and review this at pre-determined intervals or when health needs change.	Needs change with alterations in health status.	There is a record of when re-assessment is due.
The communication care plan requires an interdisciplinary approach and a protocol that is agreed and adhered to.	Many different healthcare professionals are involved in supporting the patient and a recognised procedure should facilitate communication.	The protocol has been agreed within the multidisciplinary team. An audit of patient records indicates adherence to the protocol.
Healthcare professionals are aware of the particular communication needs of ventilator-dependent patients who have a tracheostomy.	Passy-Muir valves are at present the only valves designed for use with a ventilator. Not all patients are sufficiently stable to use a valve. In addition to the restoration of speech, specialised speaking valves for use with patients on a ventilator may be beneficial in the weaning process and decrease secretions effecting considerable improvement in wellbeing (Dikeman & Kazandjian 1995).	Factors that affect individual communication needs (Appendix 2) are documented in the care plan.
Ventilator-dependent patients with a tracheostomy are given the opportunity to speak and communicate with minimal assistance.	Patients with respiratory stability who have an uncuffed tube in situ sometimes evolve vocalising techniques using the ventilator airflow, eg 'leak speech'. These techniques can be encouraged by the speech and language therapist.	
Patients have a means of summoning support and advice particularly during emergency situations.	Patients are at risk if they are unable to summon help because of communication difficulties.	Appropriate equipment is available in hospital and home to summon help, eg nurse call system, 'care call', sleep apnoea monitor, text phone and intercoms. Training in their use is given before discharge from hospital.

Key Challenges ~

- 1 *Provision of in-service education with the support of specialist speech and language therapists to develop knowledge of tracheostomy communication issues.*
- 2 *Development of guidelines and protocols relating to communication of patients with a tracheostomy.*
- 3 *Effective discharge planning to facilitate a smooth transition into the community.*
- 4 *Ensuring that access to specialist advice and support is available particularly for those patients with complex communication needs.*
- 5 *Providing additional resources for equipment and education for patients and their families in their own home.*

Section 3: Swallowing and nutrition

Key Points ~

- 1 *Swallowing difficulties may be caused by many factors (Appendix 3).*
- 2 *The presence of a tracheostomy tube may impair swallowing and can compromise patients' nutritional status. All healthcare practitioners, and registered nurses, and dietitians in particular, have an important role in ensuring the provision of good nutritional care for the patient with a tracheostomy.*
- 3 *Patients with a tracheostomy may experience loss of appetite due to the altered airway, which causes reduction in the ability to smell.*
- 4 *Patients undergoing radiotherapy may experience altered taste sensations and/or a painful, ulcerated mouth.*
- 5 *Patients should **not** be fed when they have an inflated cuff. By deflating the cuff, the effects of the tracheostomy may be reduced (Appendix 3).*

Statement	Reasons for statement	How to demonstrate statement is being achieved
Healthcare professions are knowledgeable about nutritional problems associated with patients with a tracheostomy.	Patients with a tracheostomy may have swallowing problems and be at risk from aspiration and inadequate nutrition.	Education and training on nutritional issues is provided to develop and update the knowledge of nurses working with patients with a tracheostomy.
An appropriately trained nurse will undertake an initial assessment of swallowing function and recognise when to involve the dietitian, speech and language therapist/ specialist help, and do so without delay.	There are many factors that can affect swallowing (Appendix 3). If problems with swallowing and nutrition are identified quickly, action can be taken to minimise the potential consequences of these problems, eg the risk of aspiration.	There are agreed criteria for referral to the speech and language therapist, the dietitian and other specialist help.
Specialist swallowing assessment by the speech and language therapist includes a history and physical examination of swallowing function.	If swallowing is fully assessed, problems are then identified and action taken to minimise their potential consequences eg the risk of aspiration, or of inadequate nutrition.	There is a record of assessment and referral in the patient's record. Where dysfunction is identified, appropriate investigations are undertaken under the guidance and professional risk assessment of the speech and language therapist, eg Modified Evans Blue Dye tests, fiberoptic evaluation of swallowing (FEES) and videofluoroscopy of swallow.
Dietitians undertake assessment of nutritional needs.	A clear prescription of nutritional requirements specific to the individual patient is required to ensure that adequate nutrition is received safely. Patients with a tracheostomy may experience loss of appetite because of reduction in sense of smell. Patients undergoing radiotherapy may experience altered taste sensations and/or a painful, ulcerated mouth/throat.	There are guidelines relating to the nutrition of patients with a tracheostomy, including the administration of naso-gastric and gastrostomy feeding. Factors that affect individual dietary intake are documented in the care plan.

Statement	Reasons for statement	How to demonstrate statement is being achieved
<p>For oral feeding, the patient should:</p> <ul style="list-style-type: none"> • be considered at risk of aspiration • NOT have the cuff inflated • be in the upright position, unless contraindicated • be given the correct food consistency and, where appropriate, have compensatory strategies as identified by the speech and language therapist. 	<p>Unless assessed otherwise, patients are at risk of aspiration. Inflated cuffs will not prevent aspiration of food (Leder and Ross 2000) (Appendix 3).</p>	<p>The nutrition care plan identifies factors to be considered for the individual.</p>
<p>Consideration should be given to:</p> <ul style="list-style-type: none"> • the speaking valve, and • effective analgesic for mouth pain. 	<p>The speaking valve may not have to be removed for oral feeding.</p>	
<p>Oral hygiene should be maintained through regular oral care.</p>	<p>Good oral health will assist effective nutrition (Serra 2000, Dikeman & Kazandjian 1995, St George's Healthcare NHS Trust 2006).</p>	
<p>For nasogastric and gastrostomy feeding, best practice guidelines should be followed.</p>	<p>(NHS QIS 2003).</p>	
<p>Following assessment, healthcare professionals plan, implement and evaluate a nutritional care plan specific to the patient's needs and review this at pre-determined intervals or when health needs change.</p>	<p>The assessment and development of a nutritional care plan which is implemented and evaluated is a clinical standard. (NHS QIS 2003). Nutritional needs change with alterations in health status.</p>	<p>Individual care plans include agreement on repeat screening intervals.</p>

Key Challenges ~

- 1 *Provision of in-service education with the support of the speech and language therapy and dietetics departments to develop knowledge of tracheostomy swallowing and nutrition issues.*
- 2 *Development of guidelines and protocols relating to nutrition of patients with a tracheostomy and multidisciplinary referrals.*
- 3 *Ensuring access to specialist advice and support particularly for those patients with complex nutritional needs.*
- 4 *Availability of swallowing assessment services, eg appropriate access to videofluoroscopy.*
- 5 *Effective discharge planning to facilitate a smooth transition from hospital to the community.*

Section 4: Stoma care

Key Points ~

- 1 Patients with a tracheostomy are at increased risk of infection.
- 2 Effective management of the stoma will aid the prevention of peristomal infection and irritation.
- 3 A well-formed tracheal tract will usually be evident about 5–7 days post-operatively; sutures, if present, can usually be removed 7–10 days after the procedure depending on the nature of the procedure.
- 4 The management requirements of a new stoma in the acute care environment and subsequently, when the patient is in the community, are different.
- 5 If the patient is undergoing radiotherapy their skin integrity will be greatly compromised, requiring further assessment and evaluation of stoma management. Advice from specialist centres regarding stoma care should be sought during this time.

Statement	Reasons for statement	How to demonstrate statement is being achieved
All patients with a tracheostomy stoma should have frequency of stoma care assessed in accordance with individual patient need.	Tracheostomy stomas are a potential avenue for respiratory tract infection and potential site of peristomal infection. Clean technique is advocated as the skin is colonised with organisms.	Healthcare professionals are able to demonstrate application of the fundamental principles of infection control including clean stoma care.
All patients should have an evaluation of stomal condition documented in the patient record and an appropriate plan of care initiated.	To allow ongoing assessment of the stoma.	Incidence of peristomal infection in patients with a tracheostomy is kept to a minimum. There is documented evidence of stomal condition in the patient record and local policies/guidelines are available.
The stoma should be cleaned with normal saline and a barrier film may help to protect the surrounding skin. Cotton wool should not be used to cleanse around the stoma.	To protect the skin from tracheal secretions and encouragement of wound healing. Normal saline is non-irritant to the skin and tracheal mucosa. A barrier film may help to protect the surrounding skin following an assessment of patient need. There is a risk of inhalation of fibres from cotton wool.	Healthcare professionals are aware of the risks and benefits of applying barrier film and methods to encourage wound healing.
Use of dressings around the stoma site is not always necessary but can help to absorb secretions and aid comfort for silver tubes.	Tracheostomy tubes have soft flanges (except silver tubes) that do not always require a dressing between the tube and the skin. Dressings can provide an ideal environment for bacterial multiplication.	Healthcare professionals are knowledgeable in the types of dressings available and able to select the most appropriate one based on an assessment of patient need. Local policies and guidelines are available on wound care products.

Statement	Reasons for statement	How to demonstrate statement is being achieved
If dressings are indicated, based on clinical need, gauze swabs should not be used. A manufactured tracheostomy dressing is recommended, preferably slim-line to cause minimal displacement of the tube.	Fibres may break off the gauze swabs and enter the respiratory tract.	The type of dressing is documented in the patient record.
Ties securing the tracheostomy tube should be checked for security prior to undertaking any procedure especially following removal of the flange sutures.	To reduce the incidence of accidental tube dislodgement	Tracheostomy tubes remain secure.
Patients and/or carers are taught to manage their own stoma care prior to discharge.	To encourage independence in patients with a tracheostomy.	There is documented evidence that the patient and carer have been taught to care for stoma. Patients and carers are aware of the importance of keeping the stoma clean and avoiding use of aerosols and talc around the stoma site.

Key Challenges ~

- 1 *Development of local policies/guidelines relating to tracheostomy stoma care.*
- 2 *Development of evidence to support current practice.*
- 3 *Ensuring patients with a tracheostomy and their carers are confident and competent in stoma care prior to discharge.*
- 4 *Providing patients and their families with information on caring for their stoma.*

Section 5: Tracheostomy tube management

Key Points ~ General tube management

- 1 *There is a variety of tracheostomy tubes available. Tracheostomy tubes are made from either plastic or silver. All fit into the following categories: cuffed/uncuffed; fenestrated/unfenestrated; double/single cannula; minitracheostomy; and those with an adjustable flange. Each tube type requires specific management*.*
- 2 *Staff involved in tracheostomy management should be aware of the surgical technique used to form the tracheostomy, ie open or percutaneous, as tube management will vary accordingly.*
- 3 *Many tracheostomy tubes have inner cannulae; some are disposable, but some are designed to be cleaned and reused for the same patient.*
- 4 *Effective tube management combined with suction and humidification can reduce the incidence of complications in the tracheostomy patient and is integral to the reduction of clinical risk.*
- 5 *The patient and a carer or relative should be confident and competent in tube management prior to discharge from hospital.*

Statement	Reasons for statement	How to demonstrate statement is being achieved
Individual assessment of the most appropriate tube should be made by the multidisciplinary team taking into account the patient's preference.	Consideration needs to be given to: <ul style="list-style-type: none"> • the clinical need/reason for tracheostomy • the amount of secretions • whether the patient will be taught self-care with a view to home tracheostomy care, and • whether radiotherapy is required. 	There are local assessment programmes relevant to clinical need and individual requirements.
All patients, whenever possible, will have a double cannulated tube in situ. Exceptions include patients with a minitracheostomy and paediatrics.	Tube blockage can be reduced by the use of an inner cannula that can be easily removed in an emergency. Usually tracheostomy tubes with inner cannulae do not need to be removed or changed and can be used up to 30 days in situ.	Healthcare professionals have knowledge of the tubes available and indications for use and are able to provide appropriate advice on tube usage. Healthcare professionals are knowledgeable in risk management issues and how to prevent tube obstruction.
It is good practice for the patient to have another tube available.	This minimises risk.	
If the patient is using a silver tube (which does not have an inner cannula) it should be changed every 5–7 days. This should be assessed on an individual basis as patients with excessive secretions may require more frequent changes.	This prevents infection and the tube becoming blocked with secretions.	Tracheostomy tube care is effectively managed in the clinical area.

* Tracheostomy tubes are commonly referred to by the name of the manufacturer, eg Shiley, Portex or Kapitex. Illustrations of available tubes are provided in Appendix 5.

Statement	Reasons for statement	How to demonstrate statement is being achieved
<p>The first tube change is a high risk procedure and should be undertaken under medical direction. This takes place 3–7 days after the surgical procedure (only if a tracheostomy tube with no inner cannula is used). In patients with a percutaneous tracheostomy, at least 7 days should pass before the first tube change.</p>	<p>The time delay allows a tract to become established within the trachea therefore minimising the risk of stomal closure on tube removal.</p>	<p>There are local guidelines and policies on management of the tube including information on the frequency of tube changing.</p>
<p>A note should be made of the technique used to form the tracheostomy and in particular whether the trachea is stitched up to the skin.</p>	<p>Stitches and type of suturing will affect care.</p>	<p>The patient record will contain this information.</p>
<p>Local guidelines are available for staff competent to undertake a first tube change.</p>	<p>Experienced staff are required to undertake first change of the tracheostomy tube.</p>	<p>Guidelines are available in the clinical area, and competency of staff to undertake the role is assessed.</p>
<p>Tubes with inner cannulae can remain in place for 29–31 days depending on the manufacturer.</p>	<p>The inner cannula is frequently changed therefore the outer tube patency is maintained (European Union 1993).</p>	<p>There is documented evidence of the date and ease of change. A record of outer tube changes is available in the patient's records with appropriate dates.</p>
<p>All patients with a tracheostomy have tubes cleaned or replaced as appropriate following the manufacturer's guidelines and in line with infection control policies.</p>	<p>Tubes in situ are a potential reservoir for pathogenic bacteria</p>	<p>Local policies/guidelines are available on how tracheostomy tubes are cleaned. These are in line with the manufacturer's guidelines, local infection control and decontamination policies.</p>
<p>Brushes are not used on plastic tubes unless specifically recommended by the manufacturer.</p>	<p>Brushes may cause damage to the lining of the tube.</p>	
<p>All patients with a tracheostomy have tubes replaced following the manufacturer's guidelines (Appendices 4 and 5).</p>	<p>To comply with safety regulations and prevent tube damage with inappropriate cleaning.</p>	<p>Local policies/guidelines are available on tracheostomy tube replacement in line with the manufacturer's guidelines and a written record of serial numbers and dates replaced.</p>

Statement	Reasons for statement	How to demonstrate statement is being achieved
In addition to standard resuscitation equipment, all patients with a tracheostomy in hospital require the following equipment to be readily accessible for emergency procedures: <ul style="list-style-type: none"> • tracheal dilators • a cuffed tracheostomy tube and an uncuffed tracheostomy tube the same size as the patient is wearing • a tracheostomy tube smaller than the size the patient is wearing • stitch cutters, and • 10ml syringe. 	To comply with safety regulations. To ensure appropriate equipment is available in an emergency. Use of a 20 ml syringe as part of the resuscitation equipment may pose a risk of overinflation of a cuffed tracheostomy tube and subsequent damage to the trachea.	Location of emergency equipment is clearly stated in local protocols. Healthcare professionals are aware of how to resuscitate a patient with a tracheostomy.
All patients for whom decannulation is considered should be individually assessed by the multidisciplinary team.	This will facilitate safe and effective decannulation and avoid re-insertion of tracheostomy.	There are local policies and guidelines on the decannulation procedure.
Monitoring and observation of the patient takes place during decannulation.	To allow early detection of any difficulties during/after the process.	
Tracheal dilators and a smaller sized tracheostomy tube are available at the patient's bedside during the decannulation process.	Emergency equipment is available to manage any respiratory difficulties.	
Following tube removal, an airtight dressing is placed over the stoma.	To encourage the stoma to close as quickly as possible with minimal damage to skin integrity.	The stoma closes with minimal skin damage from the dressing.

Key Points ~ Inner cannula management

- 1 *Inner cannulae reduce the lumen of the outer tracheostomy tube increasing respiratory effort.*
- 2 *Inner cannulae are designed to allow easy removal for cleaning without having to remove the outer tube.*

Statement	Reasons for statement	How to demonstrate statement is being achieved
All patients with a tracheostomy tube with an inner cannula require individual assessment of the frequency of inner cannula care.	To ensure the inner cannula remains free from secretions.	Documentation identifies the: <ul style="list-style-type: none"> • type of tube in situ • amount of secretions the patient produces, and • frequency of cleaning.

Statement	Reasons for statement	How to demonstrate statement is being achieved
The inner cannula is cleaned with warm water and air-dried in accordance with infection control requirements prior to re-insertion.	Tubes in situ are a potential reservoir for pathogenic bacteria.	It is documented that tracheostomy inner cannulae are cleaned and stored in line with the manufacturer's guidelines, local infection control and decontamination policies.

Key Points ~ Cuffed tracheostomy tubes

- 1 *Cuffed tracheostomy tubes are used to protect the airway.*
- 2 *Patients who are ventilated often have a cuffed tracheostomy tube; exceptions may be home-ventilated patients.*
- 3 *Appropriate management of a cuffed tube can prevent damage to the tracheal mucosa.*
- 4 *Tracheostomy tubes have a low-pressure cuff that removes the need to deflate the cuff on a regular basis.*
- 5 *Manometers to measure cuff pressure, with staff competent in their use, should be available.*
- 6 *If a tracheostomy mask is to be used in combination with a cuffed tracheostomy tube, users may wish to consider employing a mask manufactured from a rigid material, which is less likely to occlude the connector on the tracheostomy tube even if displaced (Scottish Healthcare Supplies 2001).*

Statement	Reasons for statement	How to demonstrate statement is being achieved
All cuffed tracheostomy tubes have cuff pressure checked twice daily maintaining pressure between 15–30 cmH ₂ O using a manometer.	Cuff pressure above 30 cmH ₂ O may cause damage to the tracheal mucosa. If the pressure is below this, aspiration may occur.	Local protocols or guidelines on recording of cuff pressure are available. Pressure is documented within the nursing records.
Manometers require careful management. Minimal occlusion volume techniques that do not require the use of a manometer may have to be employed as an alternative.	Manometers may break, or become damaged, and therefore, less reliable. Alternative volume management techniques may be developed by the experienced healthcare professional, patient and carer.	

Key Points ~ Fenestrated tubes

- 1 *Fenestrated tubes may be cuffed or uncuffed.*
- 2 *Fenestrated tubes are used to encourage weaning from the tracheostomy and also for voicing.*
- 3 *Fenestrated tubes are supplied with two inner cannulae; one is fenestrated and one is not.*

Statement	Reasons for statement	How to demonstrate statement is being achieved
All patients with a fenestrated tracheostomy tube have the fenestrated inner cannula removed prior to tracheal suction and replaced with an unfenestrated inner cannula.	It is possible to insert the suction catheter through the fenestration causing damage to the tracheal wall.	Healthcare professionals receive training in the use of fenestrated tracheostomy tubes.
All patients with a fenestrated tube require an unfenestrated tube to be readily accessible for use in an emergency.	To allow ventilation with emergency equipment as air will exit via the fenestration.	

Key Challenges ~

- 1 *Development of local policies/guidelines relating to all aspects of tracheostomy tube care.*
- 2 *Provision of educational resources to develop new skills and teach/supervise less experienced staff.*
- 3 *Development of evidence to support current practice.*
- 4 *Assessing the competence of healthcare professionals to undertake the high risk procedure of the first tube change.*
- 5 *Ensuring carers and patients, if able, are educated in all aspects of tube management and are confident and competent in managing the tube prior to the patient's discharge from hospital.*

Section 6: Suctioning

Key Points ~

- 1 *The frequency of tracheal suctioning should be assessed on an individual patient basis and should only be carried out when the patients are unable to clear their own airway effectively.*
- 2 *Suctioning should maximise removal of secretions with minimal tissue damage and hypoxia.*
- 3 *Standard infection control precautions should be applied, including good hand hygiene and use of personal protective equipment (PPE).*
- 4 *Suction equipment should be easily accessible and must be checked regularly.*
- 5 *Patients who have difficulty clearing secretions may require referral to a physiotherapist.*
- 6 *Individual assessment of the patient will determine whether suction equipment is required at home.*

Statement	Reasons for statement	How to demonstrate statement is being achieved
<p>Where possible, the lowest effective pressure should be used.</p> <p>The working group recommends a suction pressure below 120 mmHg, and no more than 200 mmHg (26.7 kPa) as a maximum and only if necessary in adults.</p>	<p>There is a requirement to set suction levels which are safe and effective (Donald 2000).</p> <p>Pressures in excess of 26.7kPa (200 mmHg) can result in greater mucosal trauma (Young 1984).</p> <p>There is a risk of atelectasis if suction pressure is too high (Glass & Grap 1995, Caroll 1994).</p> <p>Low pressures are less effective and prolong suction time (Lomholt 1982).</p>	<p>Education programmes inform healthcare staff on risks associated with tracheal suctioning.</p>
<p>Suctioning should last no longer than 10 seconds at a time.</p> <p>Appropriately sized, single-use multi-eyed or closed system, multi-use catheters are used.</p> <p>Suctioning should only be applied to the catheter as it is withdrawn.</p>	<p>Prolonged suctioning results in hypoxia.</p> <p>Tracheal suctioning can cause tracheal mucosal damage.</p> <p>Multi-eyed catheters cause least trauma (Odell et al 1993).</p> <p>Applying suction to the catheter when inserting can be difficult and damaging to the tracheal mucosa.</p>	<p>Local policies provide guidance on appropriate suctioning technique and address the following issues:</p> <ul style="list-style-type: none"> • the process for selecting the correct size of suction catheter • determining depth of suctioning, ie how far to insert suction catheter, and • ensuring that suction is applied only on removal of the suction catheter.

Statement	Reasons for statement	How to demonstrate statement is being achieved
<p>Hyperoxygenation takes place prior to procedure or in line with hospital policy.</p> <p>Caution should be taken with patients with chronic obstructive pulmonary disease (COPD).</p>	<p>To minimise risk of hypoxia associated with suctioning.</p>	<p>This is documented in the patient's records.</p>
<p>If a fenestrated tube is in situ, a plain inner tube should be inserted prior to suctioning.</p> <p>Healthcare staff are aware of the psychological effect of suctioning on patients.</p> <p>Healthcare staff are aware of local infection control policy and the implications for tracheal suction.</p>	<p>It is possible to insert the suction catheter through the fenestration causing damage to the tracheal wall.</p> <p>As patients are unable to inspire during the suction procedure anxiety levels are increased.</p> <p>There is a risk of contamination of equipment, cross infection and exposure of healthcare staff to tracheal secretions.</p>	<p>This is documented in the patient's records.</p> <p>Information is available in a variety of accessible formats to promote patient understanding and reduce anxiety.</p> <p>A local infection control policy addresses issues and precautions required in relation to tracheal suctioning.</p>

Key Challenges ~

- 1 *Ensuring appropriate equipment is readily available, including correct catheter size and type.*
- 2 *Providing regular in-service training for staff working with patients with a tracheostomy.*
- 3 *Providing support for patients and families.*
- 4 *Ensuring the patient understands the procedure.*
- 5 *Providing support and teaching of suctioning technique for patients and families.*

Section 7: Humidification

Key Points ~

- 1 *The normal humidification and filtration system is bypassed in patients with a tracheostomy; humidification must be artificially supplemented.*
- 2 *It is vital that a patient with a tracheostomy remains well hydrated and has some form of humidification, as the mucous membranes are drier in a dehydrated patient, reducing mucociliary transport and causing retention and thickening of secretions.*
- 3 *Additional safety considerations are required when a cuffed tracheostomy tube is in situ. Due to the increased risk of airway obstruction, a T-piece should be used when delivering nebulised drugs or humidified gas (Scottish Healthcare Supplies 2001, Scottish Healthcare Supplies 2003).*
- 4 *Humidification systems are a potential reservoir for infection. Individual systems should be chosen appropriately for each individual patient following risk assessment, and managed correctly according to local protocols and infection control policy.*
- 5 *The need for humidification in patients with a tracheostomy is ongoing. A range of products is available for providing humidification in the patient's home environment.*

Statement	Reasons for statement	How to demonstrate statement is being achieved
Healthcare staff undertake assessment of humidification needs in tracheostomy patients.	The 'normal' humidification and filtration system is bypassed in patients with a tracheostomy.	There is documented evidence of humidification assessment in the patient's records.
Healthcare professionals are aware of particular problems associated with artificial humidification in tracheostomy patients.	Excessive artificial humidification of inspired gases may cause as much harm as under-humidification. Heated systems are prone to 'rain out' when water vapour cools and collects in the tubing. The weight of water-based systems can pull on tracheostomy masks causing increased risk of airway obstruction when a cuffed tube is in situ. A T-piece should always be used (Scottish Healthcare Supplies 2001). Distilled water and saline reservoirs in humidification systems have been shown to be a potential source of infection (Critchley & Roulsten 1993).	Training and education programmes inform staff on the types of humidification systems available and the safe use of systems which are employed locally. An assessment of the need for a heated water system is carried out after the initial need for humidified oxygen therapy has finished. Heat and moisture exchangers are used whenever indicated as a result of assessment. Local protocols and documentation in the patient's record will demonstrate this. Humidification systems are managed in accordance with the manufacturer's instructions, local guidelines or protocols, and infection control policy.
The temperature of heated humidification should range between 37–40°C	An inspired gas temperature of 41°C or more will cause mucosal damage (Branson 1991).	There is a system to monitor inspired gas temperatures.

Statement	Reasons for statement	How to demonstrate statement is being achieved
Patients and their carers are fully aware of the need for, and appropriate use of, heat and moisture exchangers (Scottish Healthcare Supplies 2003).	Provision of appropriate information may improve patient compliance and therefore minimise long-term problems.	Appropriate up-to-date information is available in a range of accessible formats, eg written, audio, and pictorial to support verbal discussion with patients and their carers.

Key Challenges ~

- 1 *Provision of training and education to develop knowledge of healthcare staff caring for patients who require artificial humidification.*
- 2 *Development and implementation of evidence-based protocols and procedures for healthcare staff.*
- 3 *Local provision and access to a range of humidification systems and equipment.*

Appendix 1: Volume of tracheostomies in Scotland

Volume of tracheostomies (excluding laryngectomies) in Scotland Years ending 31 December 1996 – 2005

Year of main operation	Population	Volume of Tracheostomies ¹	
		number	rate
1996	5,092,190	507	9.96
1997	5,083,340	682	13.42
1998	5,077,070	795	15.66
1999	5,071,950	839	16.54
2000	5,062,940	909	17.95
2001	5,064,200	874	17.26
2002	5,054,800	938	18.56
2003	5,057,400	823	16.27
2004	5,078,400	903	17.78
2005	5,094,800	983	19.29

Source: Information Services Division (ISD), SMR01 data

¹ Based on all operations during the patients' stay.

ICD10 codes - E42 (excluding E425, E426 and E427)

Appendix 2: Factors that affect communication

An extensive range of speaking valves is available and the majority of patients can achieve voice (phonation) unless the structures involved in phonation or articulation are impaired. Best practice is to achieve communication.

- 1 Speaking valves are used with uncuffed tracheostomy tubes.
- 2 Using a speaking valve with a cuffed tracheostomy must be done with the cuff fully deflated and with extreme caution. Failure to deflate the cuff would lead to respiratory arrest.
- 3 To achieve consistent and effortless voicing, the type and size of the tracheostomy tube may need to be changed. If voicing is not easily achieved, involvement of a speech and language therapist should be considered.
- 4 The individual care plan will record the management of speaking valves, particularly when the patient sleeps.
- 5 Some patients may need to speak by finger occlusion of the tube and in this case, hygiene should be considered.
- 6 Communication may also be affected by other factors, eg neurological, mechanical or psychological.
- 7 A combination of alternative methods of communication may be used and can support oral communication efforts, eg writing, gesture, coded eye blinks, picture/word boards, computerised communication aids. Referral to the speech and language therapist should be made if problems with communication persist.

Appendix 3 : Factors that may affect swallowing

There are several causal reasons suggested which predispose patients with a tracheostomy to aspirate (Leder & Ross 2000, Donizelli et al 2005). By deflating the cuff, the effect of the tracheostomy on swallowing may be reduced.

- 1 Compression of the oesophagus from inflated cuff.
- 2 Impaired laryngeal elevation as a result of a tethered larynx.
- 3 Reduction in laryngeal sensitivity as a result of diverted airflow.
- 4 Disruption of normal co-ordination between breathing and swallowing, particularly in ventilated patients.
- 5 Reduced effectiveness of cough to clear secretions from upper airway.
- 6 Loss of subglottic positive pressure.
- 7 Neurological or mechanical disorders.
- 8 Post-operative pain and/or oedema.
- 9 Radiotherapy pain and/or oedema.
- 10 Excessively dry mouth (xerostomia) may be due to side effects of medication.

Appendix 4: Types of tracheostomy tube

Tube type	Cleaning recommendations – in accordance with health and safety regulations and manufacturer’s instructions	Tube replacement
Single use	The tube must not be cleaned and re-used since it is for single use only.	Single use only.
Single patient use	Clean with warm water and air dry the tube, and store in accordance with local policy, ready to be used by the same patient.	Every 29–31 days as required by specific manufacturer.
Reusable (silver)	Clean with a non-abrasive brush and store dry. If secretions are particularly sticky, the tube can be soaked in sodium bicarbonate solution.	Whenever the patient no longer requires this type of tube or the tube is damaged. <i>(These tubes can be sterilised and used again for different patients.)</i>

Appendix 5: Illustrations

Anatomy

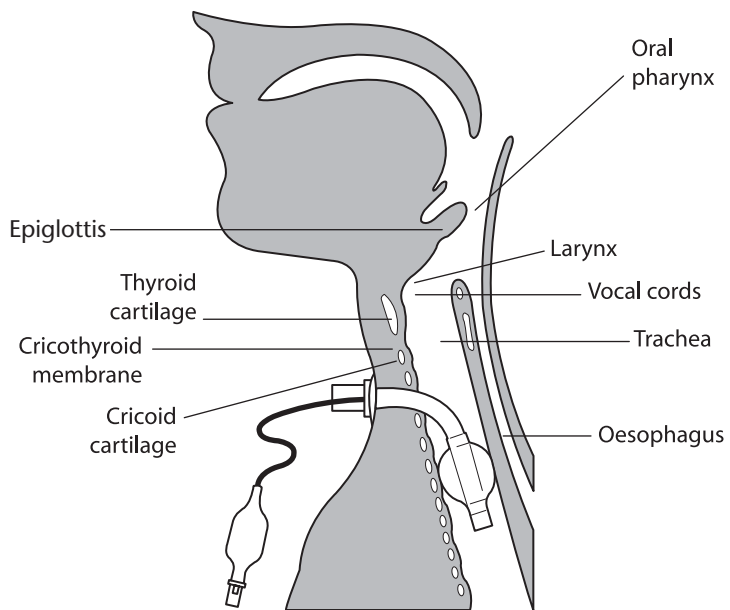

Single cannulated tube

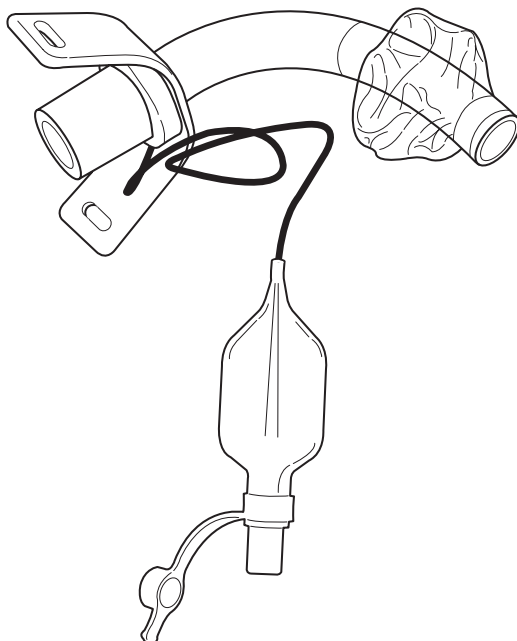

Uncuffed double cannula tracheostomy tube

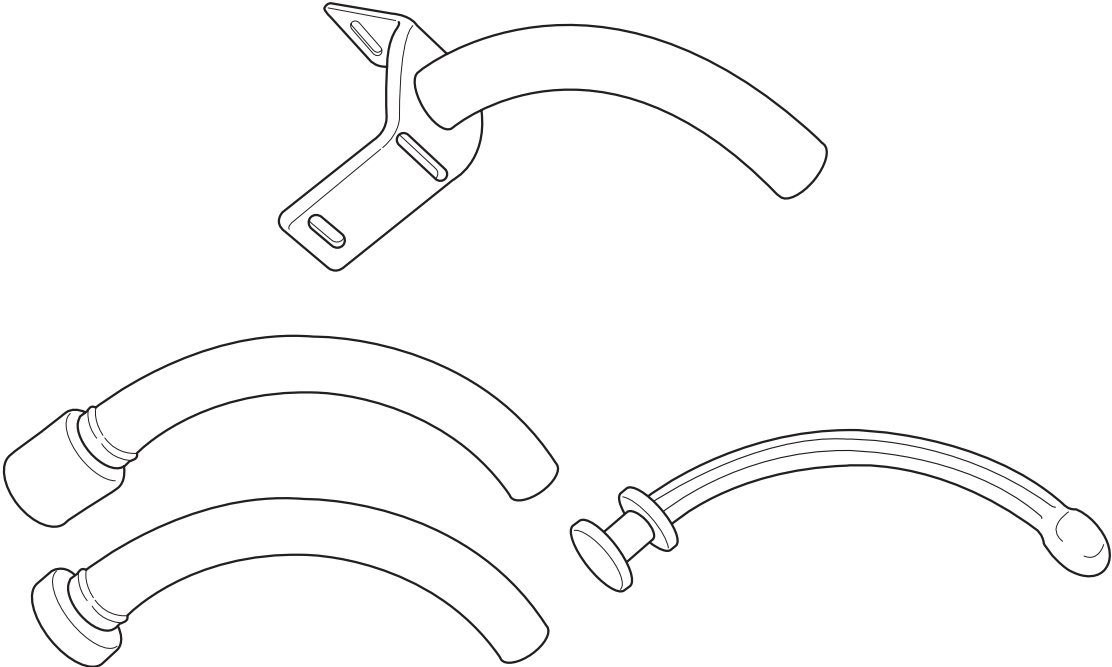

Cuffed double cannula tracheostomy tube

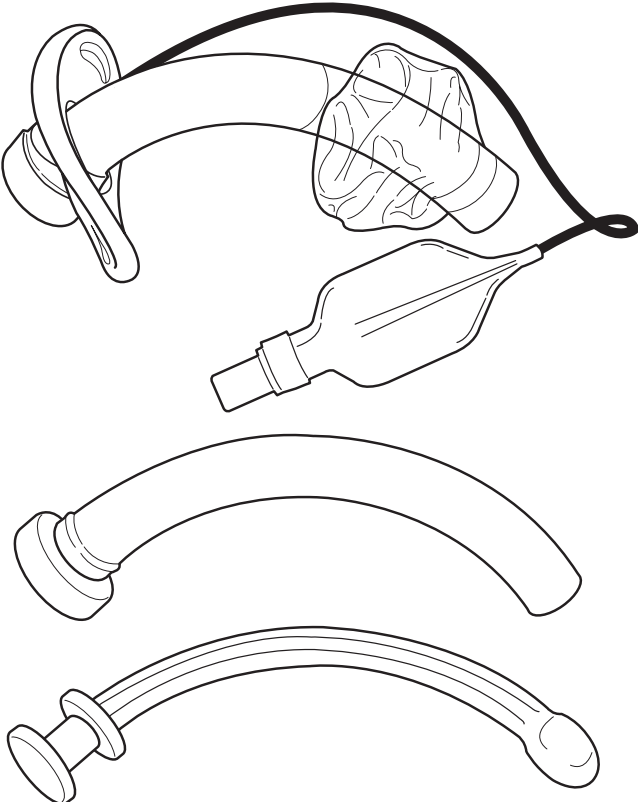

Uncuffed fenestrated tube

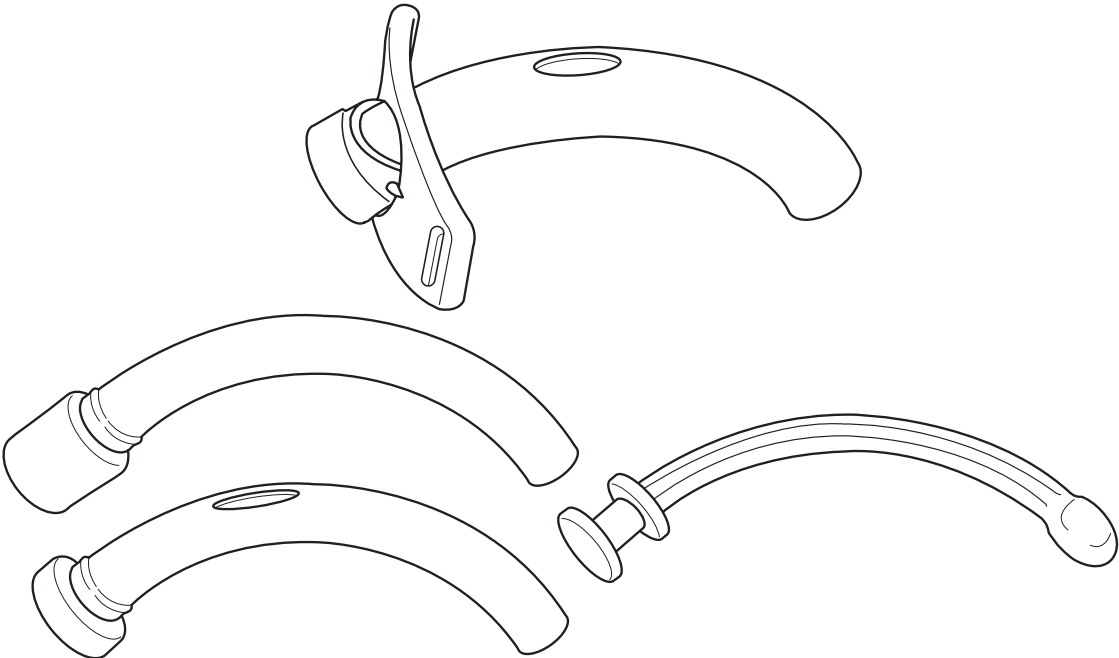

Cuffed fenestrated tube

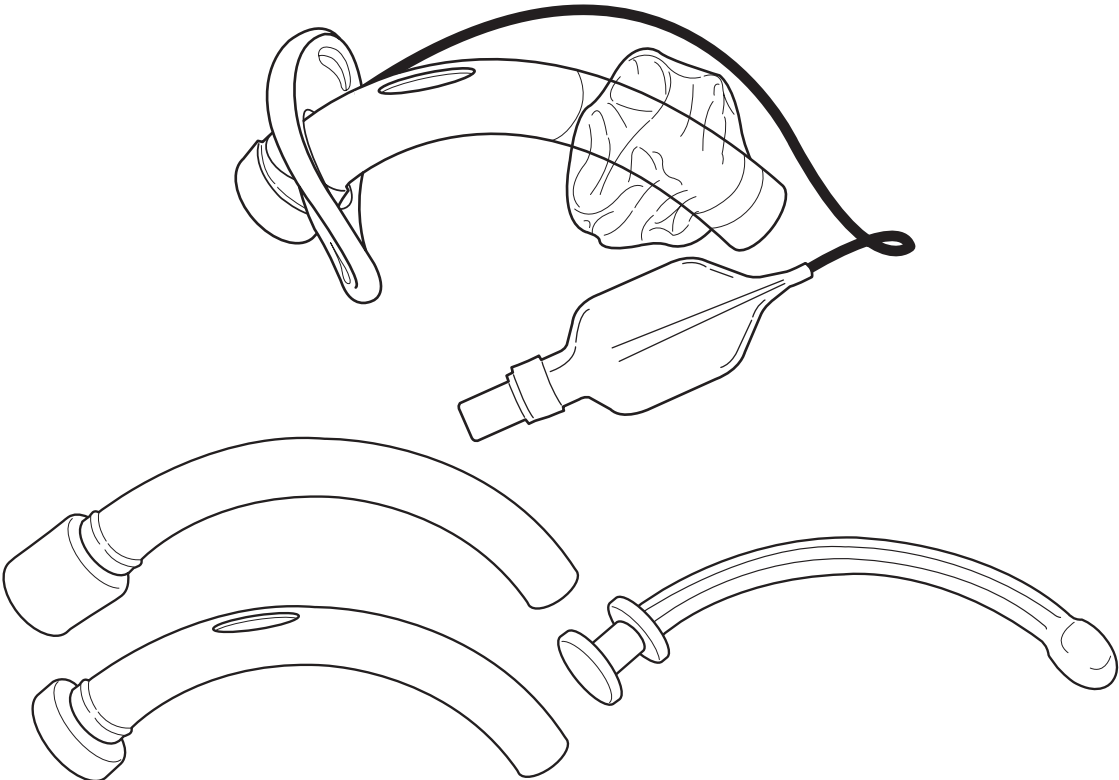

Mini tracheostomy

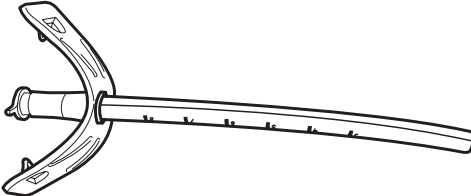

Speaking valve

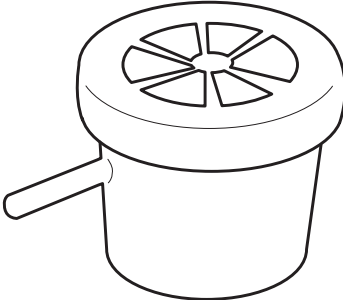

Appendix 6: Audit tool

Audit tool, to identify good practice as outlined in the best practice statement on caring for the patient with a tracheostomy

1	<i>Education and Training</i>	Y	N	Action
	Education is provided to fulfil local need, and update knowledge of healthcare professionals working with patients with a tracheostomy. This includes aspects of tracheostomy management in the context of patient-centred care, infection control and risk management, and covers aspects of care listed below.			
1a	Communication.			
1b	Swallowing and nutrition.			
1c	Methods of encouraging wound healing, types of dressings available, and assessment of these in relation to clinical need.			
1d	Tubes available and indications for use.			
1e	Tube use, cuff tube management and management of risk of tube obstruction.			
1f	The types of humidification systems available and the safe use of systems which are employed locally.			
1g	Tracheal suctioning procedures and risks.			
1h	Resuscitation of a patient with a tracheostomy.			
1i	Location of emergency equipment.			
2	<i>Local protocols, policies or guidelines</i>			
	There are local written agreements or protocols on all aspects of care of the patient with a tracheostomy.			
2a	There are written criteria agreed by the multidisciplinary team, for referral to the: <ul style="list-style-type: none"> • speech and language therapist • physiotherapist • dietitian, and • psychologist. 			
2b	There is an agreed protocol on the management of communication issues, including: <ul style="list-style-type: none"> • the use of speaking valves, and • potential involvement of the speech and language therapist to encourage vocalising techniques. 			
2c	There are guidelines relating to the nutrition of patients with a tracheostomy, including the administration of naso-gastric and gastrostomy feeding.			
2d	Local policies/guidelines relate to: <ul style="list-style-type: none"> • stomal condition • wound care products, and • tube management. 			
	These are in line with the manufacturer's guidelines and include information on: <ul style="list-style-type: none"> • the frequency of tube changing • a written record of serial numbers and dates replaced • procedures for tube cleaning in line with infection control guidelines, and • procedures on cuff management and use of manometer. 			
2e	Guidelines are available in the clinical area and competency of staff to undertake the role of the first tube change is assessed.			
2f	Location of emergency equipment is clearly stated in local protocols.			

		Y	N	Action
2g	Local policies provide guidance on appropriate suctioning technique and address the following issues: <ul style="list-style-type: none"> • the process for selecting the correct size of suction catheter • determining depth of suctioning ie how far to insert suction catheter • ensuring that suction is applied only on removal of the suction catheter • hyperoxygenation prior to suctioning, with risk alert for patients with COPD. 			
2h	A local infection control policy addresses issues and precautions required in relation to tracheal suctioning.			
2i	Patients and carers are able to summon help in an emergency.			
3	Patient care plan/Patient clinical record			
3a	Stomal condition is documented.			
3b	The type of dressing is documented.			
3c	There is documented evidence of the: <ul style="list-style-type: none"> • date • serial number • ease of tube change, and • monitoring of the security of tapes holding the tube in situ. 			
3d	There is documented evidence of humidification assessment in the patient's records.			
3e	There is a record that an assessment of the need for a heated water system is carried out after the initial need for humidified oxygen therapy has finished.			
3f	There is a record of suctioning activity and discussion and the use of information to promote patient understanding and reduce anxiety about suctioning.			
3g	There is a record of swallowing assessment and referral.			
3h	Factors that affect individual dietary intake are documented (Appendix 3).			
3i	There is a nutritional care plan which includes agreement on repeat nutritional screening intervals.			
3j	There is a record of communication assessment and referral.			
3k	There is a record of when communication re-assessment is due.			
3l	There is a communication care plan which: <ul style="list-style-type: none"> • recognises the involvement of families and carers • includes consideration of a speaking valve • is specific to individual needs, and • is evaluated and reviewed at regular intervals or when health needs change. 			
4	Patient and carer information			
	Patient information in a variety of formats is available for all aspects of tracheostomy care, from preoperative preparation to post-operative management.			
4a	On discharge to the community, the patient and carer have information in a variety of accessible formats to promote patient understanding and reduce anxiety around: <ul style="list-style-type: none"> • stoma care • tube management • humidification • suctioning • nutrition • communication, and • summoning help in an emergency. 			

Glossary

aspiration	The entry of gastric secretions, oropharyngeal secretions or food and fluid into the tracheobronchial passages (airways) caused by dysfunction or absence of normal protective mechanisms.
atelectasis	Collapse of lung tissue preventing the exchange of carbon dioxide and oxygen as part of normal respiration.
barrier film	A protective barrier which may look like plastic skin and protects the skin from becoming red and sore.
'blue dye' test	Tracheal suctioning at set intervals following the introduction of blue dye on to the tongue. This may be modified by mixing foods and liquids with dye (the Modified Evans Blue Dye Test).
catheter	Hollow tube for removing secretions.
cuffed tube	A tube with a balloon on the end which can be inflated with air to hold the tube in position and prevent secretions entering the respiratory tract.
decannulation	Removal of the tracheostomy tube allowing 'normal' respiration to occur.
fenestrated tube	A tube which has an opening cut into the tube wall to allow the passage of air.
fibreoptic evaluation of swallowing (FEES)	A flexible endoscope is placed above the epiglottis and laryngeal function is assessed before, during and after swallowing.
gastrostomy	A feeding tube that is inserted surgically through the abdominal wall into the stomach allowing liquid feed to be delivered directly into the stomach.
heat and moisture exchanger (HME)	Device to increase moisture content of inspired (breathed in) air.
humidification system	Equipment for maintaining moisture when giving ventilation (not necessarily always oxygen).
hyperoxygenation	The use of high concentrations of oxygen before and after endotracheal suction.
leak speech	The patient utilises airflow supplied by the ventilator during the inspiratory push.



minimal occlusion volume	The gradual inflation of the tracheostomy tube cuff by 0.5 ml increments of air until no air leak is heard - using a stethoscope held just below the thyroid cartilage.
mucociliary	Lining of the respiratory tract.
multi-eyed catheter	Catheter with numerous holes around tip.
nasogastric feeding	Liquid feed delivered directly into the stomach by a narrow tube that is passed into the nose and down the oesophagus (food pipe) into the stomach.
oral feeding	Food and drink taken by mouth.
peristomal	The area surrounding the stoma.
single use	Use once only and then discard.
single patient use	Can be used more than once but on one patient only.
sleep apnoea	A sleep disorder characterised by periods of absence of breathing.
speaking valve	A valve that has a one way mechanism that allows air to enter through the tracheostomy tube but closes on expiration to redirect the airflow past the vocal cords to give speech.
stoma	The artificial opening in the patient's neck formed by the tracheostomy.
suctioning	The process of removing secretions.
tracheal tract	The tract formed by the presence of a tracheostomy tube.
tracheostomy	A surgical opening in the anterior wall of the trachea (front of neck) to facilitate breathing.
T-Tube	A device to connect a cuffed tracheostomy tube to a humidifier.
videofluoroscopy	An investigation that provides a comprehensive examination of swallowing function at different levels.
weaning process	Attempt to help patients breathe without the aid of the tracheostomy tube or ventilator.
ventilator	A machine used to assist breathing.



References

- Anon. 2003. Adult tracheostomy care. *Nurs Times*, **99**(9), 29.
- Adult Literacy and Basic Skills Unit (ALBSU). 1994. Making it happen: improving skills within the health service. London: ALBSU.
- Barber L. 2002. Improving airway care. *Nurs Stand*, **17**(5), 22.
- Barnett M. 2006. Adapting to living with a tracheostomy. *Br J Community Nurs*, **20**(1), 4-9.
- Barnett M. 2005. Tracheostomy management and care. *Br J Community Nurs*, **19**(1), 4-8.
- Bell SD. 1996. Use of Passy-Muir tracheostomy speaking valve in mechanically ventilated neurological patients. *Crit Care Nurs*, **16**(1), 63-68.
- Bier J, Hazarian L, McCabe D and Perez Y. 2004. Giving your patient a voice with a tracheostomy speaking valve. *Nursing (US)*, **34**(Suppl: Med/Surg Insider), 16-18.
- Borsig A and Steinacker I. 1982. Communication with the patient in the intensive care unit. *Nurs Times*, **78**(12), 1-11.
- Branson R D. 1991 Humidification of inspired gases during mechanical ventilation. *Respir Ther*; **3**(1), 55-66.
- Buglass E. 1999. Tracheostomy care: tracheal suctioning and humidification, *Br J Nurs*, **8**(8), 500-504.
- Carroll P. 1994. Safe suctioning. *Regist Nurse*, **57**(5), 32-36.
- Choate K and Barbetti J. 2003. Tracheostomy: your questions answered. *Aust Nurs J*, **10**(11), Suppl: Clinical Update 62.
- Critchley D and Roulsten J. 1993. Nurses' knowledge of nebulised therapy. *Nurs Stand*, **8**(10), 37-39.
- Dean B. 1997. Evidence-based suction management in accident and emergency: a vital component of airway care. *Accid Emerg Nurs*, **5**(2), 92-98.
- De Carle B. 1985. Tracheostomy care. *Nurs Times*, **81**(40), 50-54.
- Denison S. 2004. Decannulation of patients with long-term tracheostomies. *Nurs Times*, **100**(38), 58-59.

Deppe SA, Kelly JW, Thoi LL, Chudy JH, Longfield RN, Ducey JP, Truwit CL and Antopol MR. 1990. Incidence of Colonization, nosocomial pneumonia, and mortality in critically ill patients using a trach care closed suction system versus an open-suction system: prospective randomized study. *Crit Care Med*, **18**(12), 1389-1393.

Dikeman KJ and Kazandjian MS. 1995. Communication and swallowing: management of tracheostomized and ventilator dependant adults. London: Singular Publishing Group.

Donald KJ, Robertson VJ and Tsebelis K 2000. Setting safe and effective suction pressure. *Intensive Care Medicine* 26, 15-19.

Donizelli J, Brady S, Wesling M, Craney M 2001. Simultaneous modified Evans blue dye procedure and video nasal endoscopic evaluation of the swallow. *Laryngoscope* **111**:1746-1750.

Donizelli J, Brady S, Wesling M, Theisen M. 2005. Effects if the removal of the tracheotomy tube on swallowing during the fiberoptic endoscopic examination of the swallow(FEES) *Dysphagia* **20**, 283-289.

Edgton-Winn M and Wright K. 2005. Tracheostomy: a guide to nursing care. *Aust Nurs J*, **13**(5), 17-20.

European Union. 1993. Council directive concerning medical devices. EU 93/42/EEC. Brussels: EU.

Ferber T. 2006. Tracheostomy care for community nurses: basic principles. *Br J Community Nurs*, **11**(5), 186-93.

Glass CA and Grap MJ. 1995. Ten tips for safer suctioning. *Am J Nurs*, **95**(5), 51-53.

Griggs A. 1998. Tracheostomy: suctioning and humidification. *Nurs Stand*, **13**(2), 49-53.

Harkin H. 1998. Tracheostomy management. *Nurs Times*, **94**(21), 56-58.

Harkin H and Russell C. 2001. Tracheostomy patient care. *Nurs Times*, **97**(25), 34-36.

Harkin H and Russell C. 2001. Preparing the patient for tracheostomy tube removal. *Nurs Times*, **97**(26), 34-36.

Harris RB. 1984. National survey of aseptic tracheotomy care techniques in hospitals with head and neck/ENT surgical departments. *Cancer Nurs*, **7**(1), 23-32.

- Harris RB and Hynman RB. 1984. Clean vs sterile tracheotomy care and level of pulmonary infection. *Nurs Res*, **33**(2), 80-85.
- Hooper M. 1996. Nursing care of the patient with a tracheostomy. *Nurs Stand*, **10**(34), 40-43.
- Jackson D and Albamonte S. 1994. Enhancing communication with the Passy-Muir valve. *Paediatr Nurs*, **20**(2), 149-153.
- Kagan C. ed. 1985. Interpersonal skills in nursing research and applications. London: Croom-Helm.
- Kapitex Healthcare. 2001. *Making things clearer for tracheostomy patients* England: Kapitex Healthcare.
- Laws-Chapman C. 1998. How to guides: tracheostomy tube management. *Care of the Critically Ill*, **14**(5) S.
- Leder SB and Ross DA. 2000 Investigation of the causal relationship between tracheotomy and aspiration in the acute care setting. *Laryngoscope* **110** 641-644.
- Lomholt N. 1982 Design and function of tracheal suction catheters. *Acta Anaesth. Scand*; **26** (b) 1-3.
- McEleney M. 1998. Endotracheal suction. *Prof Nurs*, **13**(6), 373-376.
- Mallet J and Dougherty L. eds. 2000. The Royal Marsden manual of clinical nursing procedures. 5th edition. Oxford: Blackwell Scientific.
- Mallinckrodt Medical Inc. 1993. *Tracheostomy tube: adult home care guide*. California: Mallinckrodt.
- Manzano JL, Lubillo S, Henriquez D, Martin JC, Perez MC and Wilson DJ. 1993. Verbal communication of ventilator dependent patients. *Crit Care Med*, **21**(4), 512-517.
- Marks L and Rainbow D. 2001. *Working with Dysphagia*. Oxford: Speechmark.
- Mirza S and Cameron DS. 2001. The tracheostomy tube change: a review of techniques. *Hosp Med*, **62**(3), 158-163.
- Myers EN, Johnson JT and Murry T. eds. 1998. *Tracheotomy: airway management, communication and swallowing*. London: Singular Publishing Group.

National Patient Safety Agency. 2005. *Protecting patients who are neck breathers - Patient safety information 02*. London: NHS National Patient Safety Agency.

NHS Quality Improvement Scotland. 2003. *Nasogastric and gastrostomy tube feeding for children being cared for in the community: best practice statement*. Edinburgh: NHS QIS. [under review] www.nhshealthquality.org

NHS Quality Improvement Scotland 2003 *Food, fluid and nutritional care in hospitals: Clinical Standards* Edinburgh NHS QIS www.nhshealthquality.org

Odell A, Alder A, Bayne R, Everett C, Scott S, Still B and West S. 1993. Endotracheal suction for adult, non-head injured, patients: a review of the literature. *Intensive Crit Care Nurs*, **9**(4), 274-278.

O'Neil-Pirozzi TM, Lisiecki DJ, Jack Momose K, Connors JJ, Milliner MP. 2003 Simultaneous modified barium swallow and blue dye tests; a determination of the accuracy of blue dye test aspiration findings. *Dysphagia* **18** 32-38.

Passy Muir Inc. 1989. *Tracheostomy and ventilator speaking valves*. Irvine, USA: Passy Muir Inc. www.passy-muir.com

Russell C. 2005. Providing the nurse with a guide to tracheostomy care and management. *Br J Nurs*, **14**(8), 428-33.

Scottish Healthcare Supplies. 1998. Safety Action Notice 98/34. Edinburgh: Scottish Healthcare Supplies. <http://www.show.scot.nhs.uk/shs/>

Scottish Healthcare Supplies. 2001. Safety Action Notice (SC) 01/36. Cuffed endotracheal and cuffed tracheostomy tubes: inappropriate combination with other breathing system components. Available from Internet: http://www.shs.scot.nhs.uk/hazards_safety/sanpdf/san0136.pdf [accessed 18 January 2007]

Scottish Healthcare Supplies. 2003. Safety Action Notice (SC) 03/02. Inappropriate use of breathing filters, HMEs and HMEFs: risk of ineffective patient ventilation. Available from Internet: http://www.shs.scot.nhs.uk/hazards_safety/sanpdf/san0302.pdf [accessed 18 January 2007]

Sell S, Tasota F. 2004. Tracheostomy mucus plug. *Nursing*, **34**(10), 88.

Serra A. 2000. Tracheostomy care. *Nurs Stand*, **14**(42), 45-52.

Sigler BA and Schuring LT. 1993. *Ear, nose and throat disorders*. London: Mosby.

St George's Healthcare NHS Trust. 2006. Guidelines for the care of patients with tracheostomy tubes. London: Smiths-Medical Ltd.

Suiter DM, McCullough GH, Powell PW. 2003 Effects of cuff deflation and one-way speaking valve placement on swallow physiology. *Dysphagia* **18**, 284-292.

Tattersall S. 2005. Choosing a suction machine for use by patients in the community setting. *Prof Nurs*, **20**(5), 50-51.

Tippetts DC and Siebens AA. 1991. Using ventilators for speaking and swallowing. *Dysphagia*, **6**(2), 94-99.

Whyte A. 2004. A pioneering role in airways nursing care. *Nurs Times*, 100(28), 24-25.

Woodrow P. 2002. Managing patients with a tracheostomy in acute care. *Nurs Stand*, **16**(44), 39-46.

Young CS. 1984. A review of the adverse effects of airway suction. *Physiotherapy* **70**(3), 104-106.

Young CS. 1984. Recommended guidelines for suction. *Physiotherapy* **70**(3), 106-108.

Useful websites

British Association of Head & Neck Oncology Nurses

www.bahnon.org.uk

ENT information

www.ENTLinx.com

Head and Neck Oncologists' / Surgeons' Association

www.bahnon.co.uk

Information on head and neck cancers

www.headandneckcancer.org

Kapitex airway equipment

info@kapitex.com

Mallinckrodt airway equipment

www.mallinckrodt.com

Portex

www.smiths-medical.com

Who was involved in developing the statement?

Working Group

Susan Buchanan	Staff Nurse NHS Forth Valley
Lynne Coltart	Head & Neck Clinical Nurse Specialist NHS Dumfries & Galloway
Kathlyn Cowie	Clinical Educator, Ventilation Services NHS Greater Glasgow and Clyde
Rhona Davidson	Physiotherapist NHS Grampian
Catriona Don	CCN Team Leader NHS Tayside
Fiona Elder	Staff Nurse NHS Highland
Penny Gravill	Lead Speech and Language Therapist (Neurosurgery) NHS Grampian
Carolyn Guild	Clinical Manager NHS Greater Glasgow and Clyde
Lindy Manson	Education Co-ordinator NHS Lothian
Graeme McGibbon	ENT & Maxillofacial/Checklist Co-ordinator NHS Lanarkshire
Anita Nardi	Senior Staff Nurse NHS Grampian
Christine Rait	ENT Ward Manager NHS Grampian
Adam Wood	Infection Control Nurse NHS Borders

Reference Group

This group provided first consultation.

Mr Kim Ah-See	ENT Consultant NHS Grampian
Mr N Balaji	ENT Consultant NHS Lanarkshire
Dr S Bennett	Consultant Microbiologist NHS Borders
Dr T Cripps	Consultant Anaesthetist NHS Borders
Mr S Denholm	ENT Consultant: Head and Neck Surgeon NHS Highlands
Dr W T Frame	Consultant Anaesthetist NHS Greater Glasgow and Clyde
Fiona Grant	Project Manager ENT Redesign/Surgical Services Clinical Co-ordinator NHS Forth Valley
Angela Griggs	Chairperson, RCN ENT and Maxillofacial Nursing Forum Lecturer Practitioner ENT Nursing, Royal Free Hampstead NHS Trust & City University, London
Janis Harvey	Physiotherapy Clinical Specialist - Critical Care NHS Lothian
Lorraine King	Clinical Development Nurse NHS 24
Gregory Hughes	Patient Representative
Susan Marr	Community Dietitian NHS Dumfries & Galloway

Mr I McClymont	Consultant Surgeon (Head and Neck) and Chairman, Noscan NHS Highlands
Linda Prevett	Speech and Language Therapist NHS Dumfries & Galloway
Aileen Quinn	Clinical Change Governance Group NHS 24
Lesley Sabey	Beatson Oncology Centre NHS Greater Glasgow and Clyde
Cameron Sellars	Senior Speech and Language Therapist NHS Greater Glasgow and Clyde
Dr S Stott	Consultant Anaesthetist NHS Grampian
Gillian Thain	Respiratory Clinical Specialist NHS Grampian
Claire Walkington	Home Ventilation Team NHS Lothian
Sheila Wheeler	Education Advisor NHS Grampian
Miss Aileen White	Consultant Otolaryngologist NHS Greater Glasgow and Clyde
Dr D Williams	Consultant Anaesthetist NHS Dumfries & Galloway

With NHS QIS support from:

Penny Bond	Professional Practice Development Officer
Rosemary Hector	Project Co-ordinator
Clíodhna Callanan	Project Administrator

You can look at this document on our website. It is also available, if you ask:

- in electronic format
- in audio format
- in Braille
- in large print
- in community languages

NHS Quality Improvement Scotland

Edinburgh Office

Elliott House, 8-10 Hillside Crescent, Edinburgh, EH7 5EA

Phone 0131 623 4300

Glasgow Office

Delta House, 50 West Nile Street, Glasgow G1 2NP

Phone 0141 225 6999

E-mail: comments@nhshealthquality.org website: www.nhshealthquality.org

